

BAUHN®

Version 1.1

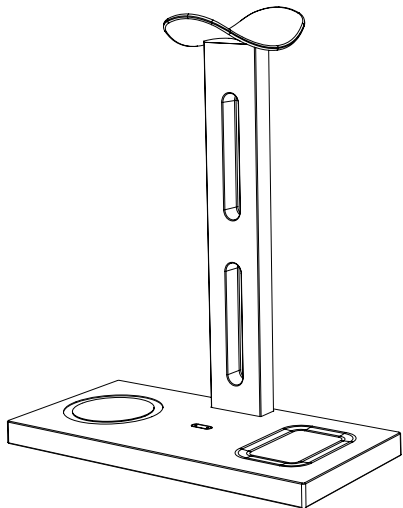

3 In 1 Charging Headphone Stand

USER GUIDE

CE220709
12/24

SAFETY WARNINGS

Read this manual thoroughly before first use and keep it in a safe place for future reference, along with the purchase receipt and carton. The safety precautions enclosed herein reduce the risk of fire, electric shock and injury when correctly adhered to. Follow all instructions and take notice of all warnings to reduce the risk of fire or electric shock.

- Do not expose this product to water, rain, moisture or dust. Electronic products of this kind should never be subjected to moisture or extreme temperatures
- Do not attempt to open the product housing. There are no user-serviceable parts inside this product
- Do not repair the unit yourself. If your device is not functioning correctly, disconnect the product from power, and contact after sales support
- Supervise young children to ensure they do not play with the product
- Do not expose to water, dust, moisture, chemicals, oils, or other liquids
- Do not expose to naked flames or other heat sources
- Do not drop or subject the device to undue shock
- Keep away from direct sunlight. Indoor use only
- Unplug this device during lightning storms or when unused for long periods of time
- **WARNING: Use only with ambient temperatures between 0-45°C degrees**
- Use of apparatus in moderate climates.
- Please keep a distance of at least 30cm between implantable medical devices (pacemakers, implantable cochlear, etc.) and the Wireless Charger, to avoid potential interference with the medical device
- Do not use damaged power cords, plugs or loose electrical sockets
- Only use original cable and reputable third-party chargers
- Do not clean the Wireless Charger with harmful chemicals or detergents
- Misuse, dropping or excessive force may cause damage to the charging pad
- Do not touch the device, power cords, plugs, or the electric socket with wet hands or other wet body parts
- Do not place other materials, like metal objects, magnets, and magnetic stripe cards, between the mobile device and the wireless charger pad

NOTE:

- *Not all phones are wireless charging compatible, check your phone specifications to ensure your phone is compatible*
- *Some phone cases may not be compatible with wireless charging*
- *When the mobile device is not placed on the charging area accurately, your mobile device may not charge properly*



BAUHN®

HEADPHONE DESK STAND

Warranty Details

REGISTER YOUR PURCHASE AT www.aldi.com.au/en/about-aldi/product-registration/ TO KEEP UP-TO-DATE WITH IMPORTANT PRODUCT INFORMATION

The product is guaranteed to be free from defects in workmanship and parts for a period of 12 months from the date of purchase. Defects that occur within this warranty period, under normal use and care, will be repaired, replaced or refunded at our discretion. The benefits conferred by this warranty are in addition to all rights and remedies in respect of the product that the consumer has under the Competition and Consumer Act 2010 and similar state and territory laws.

Our goods come with guarantees that cannot be excluded under the Australian Consumer Law. You are entitled to a replacement or refund for a major failure and for compensation for any other reasonably foreseeable loss or damage. You are also entitled to have the goods repaired or replaced if the goods fail to be of acceptable quality and the failure does not amount to a major failure.

AFTER SALES SUPPORT

1300 663 907

customercare@bakobrand.com

MODEL: CE220709 PRODUCT CODE: 718192 12/2024

1

YEAR WARRANTY

IN THE BOX

1. 3 in 1 charging headphone stand
2. USB cable
3. User guide*
4. Warranty card*

*Not pictured

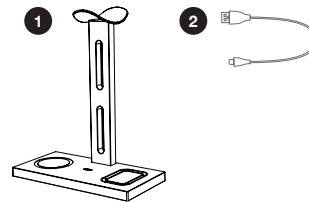

FUNCTIONS

1. Headphone bracket
2. Wireless phone charging pad
3. Indicator light
4. Wireless earbud charging pad
5. USB-A output
6. USB-C output
7. Power input

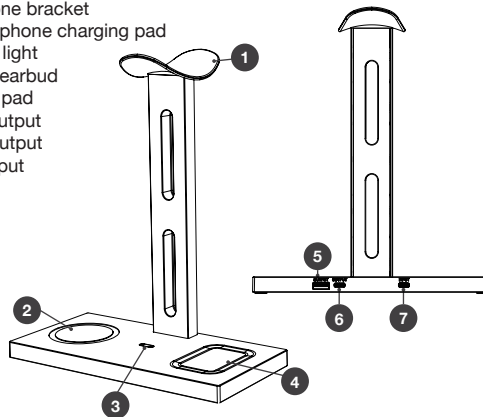

SETUP

1. Insert the headphone bracket into the base with the marked arrow facing towards the back of the stand
2. Press down firmly
3. Plug the supplied USB cable into the back of the base into the port marked 'input' and insert the other end into a USB wall adapter (not included)

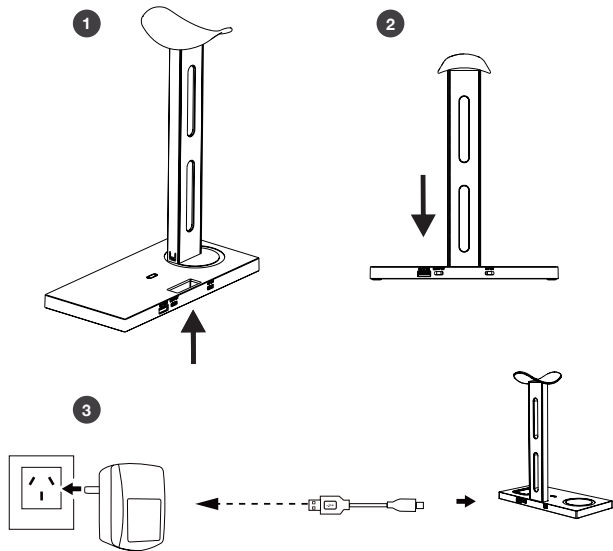

USING THE HOLDER

1. Simply place your headphones on the headphone bracket to store
2. Place wireless charging compatible device on the wireless charging pad to begin charging
3. The indicator light will slow flash to show the device is charging
4. Some cases may not be wireless charging compatible and may need you to remove your phone case to charge

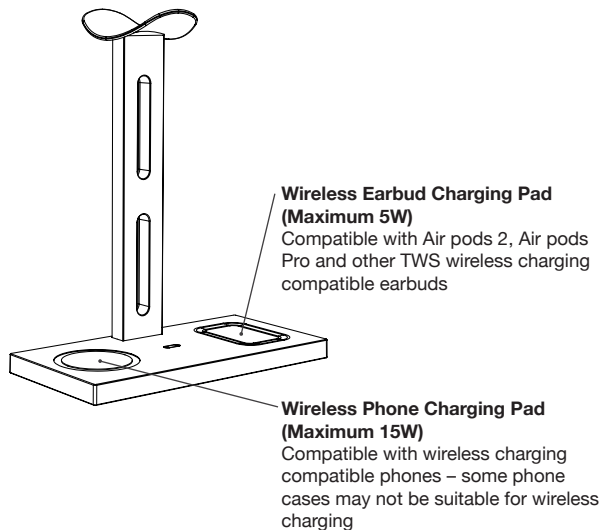

TECH SPECS

Input cable:	USB-C
Input:	5V ⚡ 2A, 9V ⚡ 2A, 12V ⚡ 3A
Wireless phone charging pad output:	15W
Wireless earbuds charging pad output:	5W
USB-A output:	10W (5V ⚡ 2A)
USB-C output:	10W (5V ⚡ 2A)
Total output:	20W

NOTE: The actual output power of the charger depends on the input power.

AFTER SALES SUPPORT

If you experience any issues with this product or its performance is not what you had expected, please contact us at Balco Brands

It is likely that we can resolve any problems for you via phone or email

We can be reached on:

Phone: 1300 663 907 (Mon - Fri; 8:30am - 6:00pm AEST)
Email: customercare@balcobrands.com
Web: www.balcobrands.com



BAUHN

HEADPHONE DESK STAND

Repair and Refurbished Goods or Parts Notice

Unfortunately, from time to time, faulty products are manufactured which need to be returned to the Supplier for repair.

Please be aware that if your product is capable of retaining user-generated data (such as files stored on a computer hard drive, telephone numbers stored on a mobile telephone, songs stored on a portable media player, games saved on a games console or files stored on a USB memory stick) during the process of repair, some or all of your stored data may be lost.

We recommend you save this data elsewhere prior to sending the product for repair.

You should also be aware that rather than repairing goods, we may replace them with refurbished goods of the same type or use refurbished parts in the repair process.

Please be assured though, refurbished parts or replacements are only used where they meet ALDI's stringent quality specifications.

If at any time you feel your repair is being handled unsatisfactorily, you may escalate your complaint. Please telephone us on 1300 663 907 or write to us at:

Balco Brands

PO Box 537 Bayswater Business Centre, Victoria, Australia

1300 663 907 - Hours: Mon-Fri 8:30am - 6:00pm AEST

customercare@balcobrands.com

AFTER SALES SUPPORT

1300 663 907

customercare@balcobrands.com

MODEL: CE220709 PRODUCT CODE: 718192 12/2024

1
YEAR WARRANTY