

WORKZONE®



6 OUTLET POWER BOARD

MANUAL

AFTER SALES SUPPORT



AUS

1300 663 907



customercare@winplus.com.au

MODEL: PB43275, 08/13, 43275



6 Outlet Power Board

Warranty Details

The product is guaranteed to be free from defects in workmanship and parts for a period of **12 months** from the date of purchase. Defects that occur within this warranty period, under normal use and care, will be repaired, replaced or refunded at our discretion. The benefits conferred by this warranty are in addition to all rights and remedies in respect of the product that the consumer has under the Competition and Consumer Act 2010 and similar state and territory laws.

Our goods come with guarantees that cannot be excluded under the Australian Consumer Law. You are entitled to a replacement or refund for a major failure and for compensation for any other reasonably foreseeable loss or damage. You are also entitled to have the goods repaired or replaced if the goods fail to be of acceptable quality and the failure does not amount to a major failure.

Contents

2	Warranty
3	Contents
4-5	Welcome / General Safety Instructions
6	Product Overview
7	Features / Technical Specifications
8-11	Instructions
12-13	FAQ'S
14	Repair and Refurbished Goods or Parts Notice



Welcome

Congratulations on choosing to buy a WORKZONE® product. By doing so you now have the assurance and peace of mind that comes with purchasing a product made by one of the leading manufacturers. All products brought to you by WORKZONE® are manufactured to the highest standards of performance and safety and, as part of our philosophy of customer service and satisfaction, are backed by our comprehensive 1 year warranty. We hope you will enjoy using your purchase for many years to come.

General Safety Instructions

Read this manual thoroughly before first use and keep it in a safe place for future reference, along with the warranty card, purchase receipt and carton. The safety precautions enclosed herein reduce the risk of fire, electric shock and injury when correctly adhered to. **Follow all instructions and take notice of all warnings to reduce the risk of fire or electric shock.**

- If your 6 Outlet Power Board repeatedly trips and turns off, check the product that you have plugged into the 6 Outlet Power Board. This may be an indicator that the product is no longer safe and will need to be checked by the product's manufacturer.
- 6 Outlet Power Board can only protect you if it is plugged directly into a fixed power point. It should not be plugged into an extension lead or another power board.
- Do not immerse in water or other liquids. Do not use the 6 Outlet Power Board in the rain.
- Keep away from liquids, oils, petrol and all chemicals.
- Using the 6 Outlet Power Board is not a substitute for basic electrical safety. Always exercise caution when operating any electrical device.

- The 6 Outlet Power Board contains no serviceable parts. Opening the product will void your warranty.
- Test the RCD before every use. Once per month, at a minimum.
- When a socket is not in use, always close protective cover fully.
- Strength of magnet attachment varies depending on the surface it is attached to. Test that magnetic strength is suitable for your application before use. Magnets are not designed to withstand strain of an extension lead/s or power cord/s plugged in to 6 Outlet Power Board.
- The 6 Outlet Power Board RCD will protect against faults to earth through the body, but not against active to neutral faults. If a fault is detected the RCD will cut power.
- Supervise young children to ensure they do not play with the product.

Product Overview

1. 6 x 240V outlets
2. Wide spaced outlets
3. On/Off switch for each outlet
4. 3 x USB Outlets
5. MCB protection
6. RCD Test button
7. RCD protection
8. Magnetic Backing
9. Tension Straps

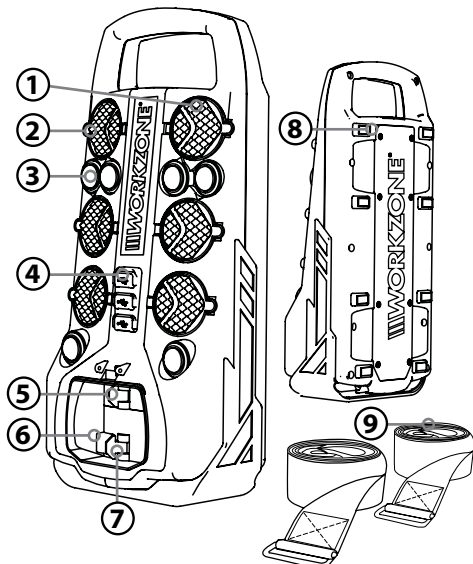

Features

Safety Features

- RCD (Residual Current Device) safety switch to protect against electrocution
- MCB (Miniature Circuit Breaker) to provide localised overload protection
- Outlet covers to protect against dust and water ingress

Product Features

- Magnetic back for attaching to metal surfaces
- Dual tension straps provided for attaching to upright supports
- USB ports for charging your phone and other devices

Technical Specifications

Voltage:	240V AC 50Hz
Max Load:	2400W
Lead:	Heavy Duty, 1.8m 1.0mm ²
Plug:	Fully Moulded
Rated Residual Current:	30mA
Typical Trip Time:	30ms
IP Rating:	IP33
USB Output:	5V DC, 2A Max

After Sales Support - Help Desk

Telephone: 1300 663 907
Email: customercare@winplus.com.au

After Sales Support - Help Desk

Telephone: 1300 663 907
Email: customercare@winplus.com.au

Instructions

1. Uncoil lead fully and mount the 6 Outlet Power Board using magnets or tension straps provided.

Magnets will attach best to metals with a high iron content, and a clean smooth surface. Steel is an example of a metal with a high iron content. Metals such as aluminium have a low iron content. **Test your attachment method and material is suitable before use.**

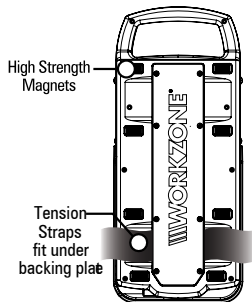
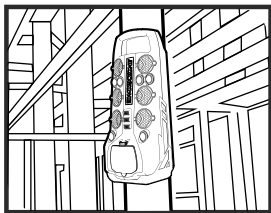

After Sales Support - Help Desk

Telephone: 1300 663 907
Email: customercare@winplus.com.au

Instructions

2. Plug the 6 Outlet Power Board into a fixed power point then turn the power point on.

Do not plug into an extension lead.

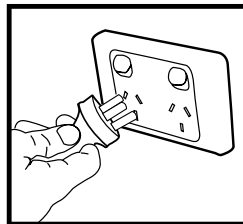

3. Lift the clear protective cover and ensure both the RCD and MCB toggle are ON.

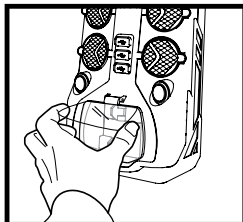

After Sales Support - Help Desk

Telephone: 1300 663 907
Email: customercare@winplus.com.au

Instructions

4. Test the RCD before each use by pressing the orange test button on the RCD. The RCD should immediately trip to the OFF position. If the RCD fails to trip "OFF" after the test button is pressed, do not use as the product may be faulty.

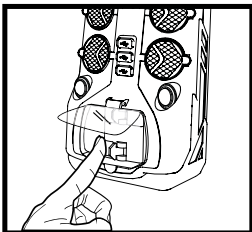

If faulty contact After Sales Support Help Desk on 1300 663 907

5. If RCD functions correctly, reset the RCD by switching the RCD toggle to ON.

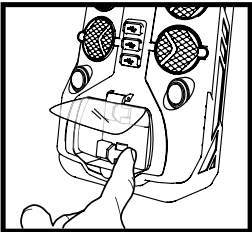

Your 6 Outlet Power Board is now ready to use. Simply plug in your tools / equipment and switch the socket to "on".

After Sales Support - Help Desk

Telephone: 1300 663 907
Email: customercare@winplus.com.au

Instructions

To reset the MCB:

If too many high current tools are plugged into your 6 Outlet Power Board, the MCB will automatically cut off the power. To restore power, remove the tools causing the overload then switch the MCB toggle to the ON position.

If the RCD or MCB repeatedly trip, seek advice from an electrical contractor or contact After Sales Support Help Desk on 1300 663 90.

Before inspection or repair of the 6 Outlet Power Board, or any connected devices, make sure to unplug all connections. Unplugging all connections is the safest way to achieve electrical isolation.

After Sales Support - Help Desk

Telephone: 1300 663 907
Email: customercare@winplus.com.au

FAQ'S

Questions	Answers
Is this product compatible with 15A sockets?	No. The maximum current of 10A applies to this product.
What does the IP rating mean?	IP stands for Ingress Protection. This product is IP33 rated. The first digit indicates the level of protection against solid particles. In this case greater than 2.5mm. The second digit indicates the level of protection against ingress of water. In this case 'spraying water.'
Does the IP rating mean I can immerse the product in water, or use in the rain?	No. Do not immerse in water or other liquids. Do not use this product in the rain.
What does MCB stand for? What does it mean?	MCB stands for Miniature Circuit Breaker. It provides protection against localised overload. This can help to protect your tools or electrical equipment from damage.
What should I do to restore power after the MCB has tripped?	To restore power, remove the tools or equipment causing the overload, then switch the MCB toggle to the ON position.
What does RCD stand for? What does it mean?	RCD stand for Residual Current Device. It is a safety switch to help protect against electrocution. In the event of leakage current, the RCD is designed to disconnect the circuit.
How often should I test the operation of the RCD?	The operation of the RCD should be tested before every use. Once per month at a minimum.

After Sales Support - Help Desk

Telephone: 1300 663 907
Email: customercare@winplus.com.au

FAQ'S

Questions	Answers
What should I do if the 6 Outlet Power Board repeatedly trips and turns off?	Check the product that you have plugged into the 6 Outlet Power Board. This may be an indication that the product is no longer safe and will need to be checked by the product's manufacturer.
What are wide spaced outlets?	Wide spaced outlets allow you to use large power adaptors without blocking the other sockets on the power board. This ensures you can have up to 6 sockets connected at one time.
Can I plug the 6 Outlet Power Board into extension leads or other power boards?	The 6 Outlet Power Board protects you best if it is plugged directly into a fixed power point. It should not be plugged into an extension lead or another power board.
Can the magnets hold to any metallic surface?	Strength of magnet attachment varies depending on the surface it is attached to. Magnets will attach best to metals with a high iron content and a clean smooth surface. Steel is an example of a metal with a high iron content. Metals such as aluminium have a low iron content. Test that the magnet strength is suitable for your application before use.

After Sales Support - Help Desk

Telephone: 1300 663 907
Email: customercare@winplus.com.au

